



NO: TB-SC-001

DATE: 2007/10/02

PAGE: 1 of 7

TECHNICAL BULLETIN

Czech Aircraft Works s.r.o.
Na Zahonech 1177
Building A10s
686 04 Kunovice -Airport
Czech Republic
tel: 00 420 572 543 456
fax: 00 420 572 543 692

REV: -

DATE: -

MODEL AFFECTED: SPORTCRUISER

SUBJECT: FLAPS CONTROL SYSTEM

ASSEMBLED AIRCRAFTS AFFECTED: All S/N with digital display flaps control system installed.

KITS AFFECTED: All S/N with digital display flaps control system installed.

COMPLIANCE: Czech Aircraft Works recommends accomplishment of this bulletin in case of unreliability of installed flaps control system.

DESCRIPTION:

This bulletin introduces more reliable flaps control system that is manually controlled with LED position indication.

APPROVAL:

The engineering design aspects of this bulletin are Czech Aircraft Works s.r.o. approved.

MANPOWER:

Aproximately 3 man-hours are required to complete this bulletin. Man-hours are based on hands-on time, and may vary with personnel and facilities available.

WARRANTY:

Owners/operators of SPORTCRUISER who comply with the instructions outlined in this bulletin will receive a special 100% warranty credit for the part contained in the "Required Material" section of this bulletin.

MATERIAL:

PART NUMBER	NOMENCLATURE	QUANTITY
POS-12	POSITION SENSOR	1
SC0411N	BRACKET	1
M3x12	BOLT	4
M3	WASHER	4
M3	NUT	4
SC412N	ROD	1
AN4-14	BOLT	1
AN960-416	WASHER	1
AN310-4	NUT	1
AN380-2-3	COTTER PIN	1
AVEX 3,2x9,5 Al/St	RIVET	5
RP3	FLAPS POSITION INDICATOR	1



NO: TB-SC-001

DATE: 2007/10/02

PAGE: 2 of 7

TECHNICAL BULLETIN

Czech Aircraft Works s.r.o.
Na Zahonech 1177
Building A10s
686 04 Kunovice -Airport
Czech Republic
tel: 00 420 572 543 456
fax: 00 420 572 543 692

REV: -

DATE: -

CONSUMABLE MATERIAL:

PART NUMBER	NOMENCLATURE	QUANTITY
SOLVENT	ACETONE, MEK, ISOPROPYL ALCOHOL	10 ml
PRIMER	ALKYD, EPOXY OR POLYURETHANE	10 ml
TOP COAT	ACRYLIC-POLYURETHANE – INTERIOR GRAY	10 ml

SPECIAL TOOLS:

No special tools required.

WEIGHT AND BALLANCE:

Insignificant.

ELECTRICAL LOAD DATA:

Insignificant.

REFERENCES:

SPORTCRUISER Maintenance and Inspection Procedures (MIP)

PUBLICATIONS AFFECTED:

SPORTCRUISER Maintenance and Inspection Procedures

ACCOMPLISHMENT INSTRUCTIONS:

1. Ensure all power is removed from the aircraft.
2. Remove left instrument panel.
3. Remove central console

NOTE:

Let removed parts connected with its wiring and tubing except of otherwise specified.

4. Left instrument panel, flaps control unit. See DRAWING 1
 - a. Disconnect RED wire (positive) from fuse „FLAPS“
 - b. Disconnect BLACK wire (GND)
 - c. Disconnect wires to flaps actuator – RED (13) and Black (14)



NO: TB-SC-001

DATE: 2007/10/02

PAGE: 3 of 7

TECHNICAL BULLETIN

Czech Aircraft Works s.r.o.
Na Zahonech 1177
Building A10s
686 04 Kunovice -Airport
Czech Republic
tel: 00 420 572 543 456
fax: 00 420 572 543 692

REV: -

DATE: -

- d. Disconnect wires (gray bandaged), (3), (9), (10). There could be used GREEN, YELLOW, BROWN, or ORRANGE, BLUE, GREEN.

NOTE:

Cable harnesses will use in modified Flaps Control system, let them in their position.

5. Remove Electronic Flaps Control Unit and Capacitors Block from the console behind the left instrument panel.
6. Remove flaps control display unit.
7. Rivet patch instead of display unit, restore painting (matt interior gray).
8. Remove access cover in baggage area. Refer to SPORTCRUISER MIP, Chapter 6.3.4
9. Remove flaps position sensor unit including console.
10. Remove Bolt AN4-23A, install Bolt AN4-14, see DRAWING 3
11. Install new Flaps position indicator RP3 on central console according PICTURE 1. Cut proper hole, restore painting (matt interior gray) if necessary.
12. Install new Flaps position sensor POS12 attached on Bracket SC411N under actuator according to Drawing 3
13. Connect POS12 to flaps control lever by the Rod SC0412N.
14. Connect wiring POS12 (GREEN, YELLOW, BROWN, or ORRANGE, BLUE, GREEN) to RP3 Flaps position LED indicator according to Drawing 3
15. Connect wiring RP3 to Flaps fuse (RED) and Ground (BLACK) according to Drawing 3
16. Connect wiring to flaps control switch according to Drawing 3.
17. Check wiring for proper attachment, insulation, security.
18. Install removed instrument panel and central console, install access covers.
19. Install and connect power to the aircraft.
20. Perform functional ground check of flaps control system.
21. Restore aircraft to the airworthy condition.
22. Anotate aircraft records to reflect compliance with this bulletin

TECHNICAL BULLETIN

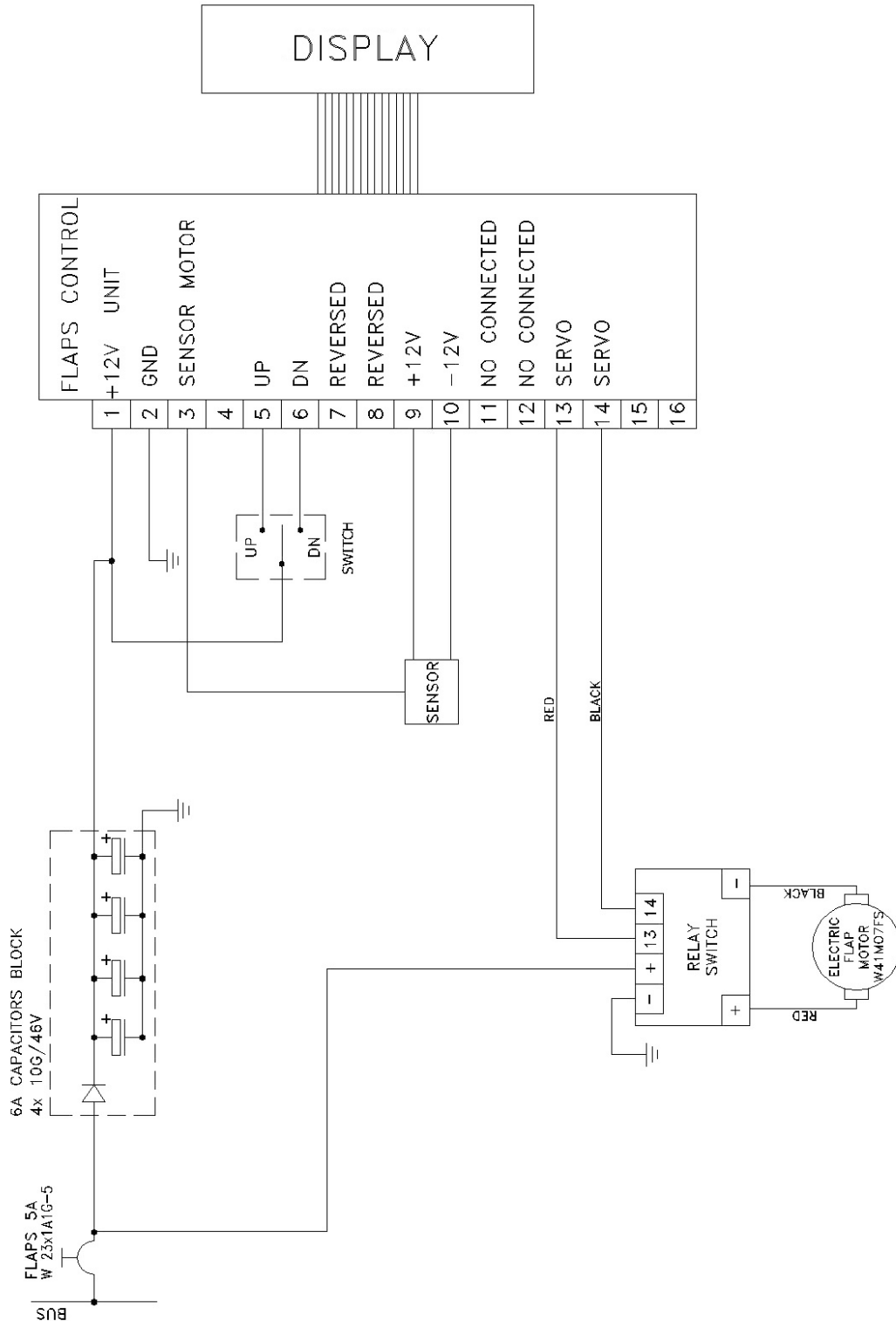

DRAWING 1 – INITIAL SITUATION

TECHNICAL BULLETIN

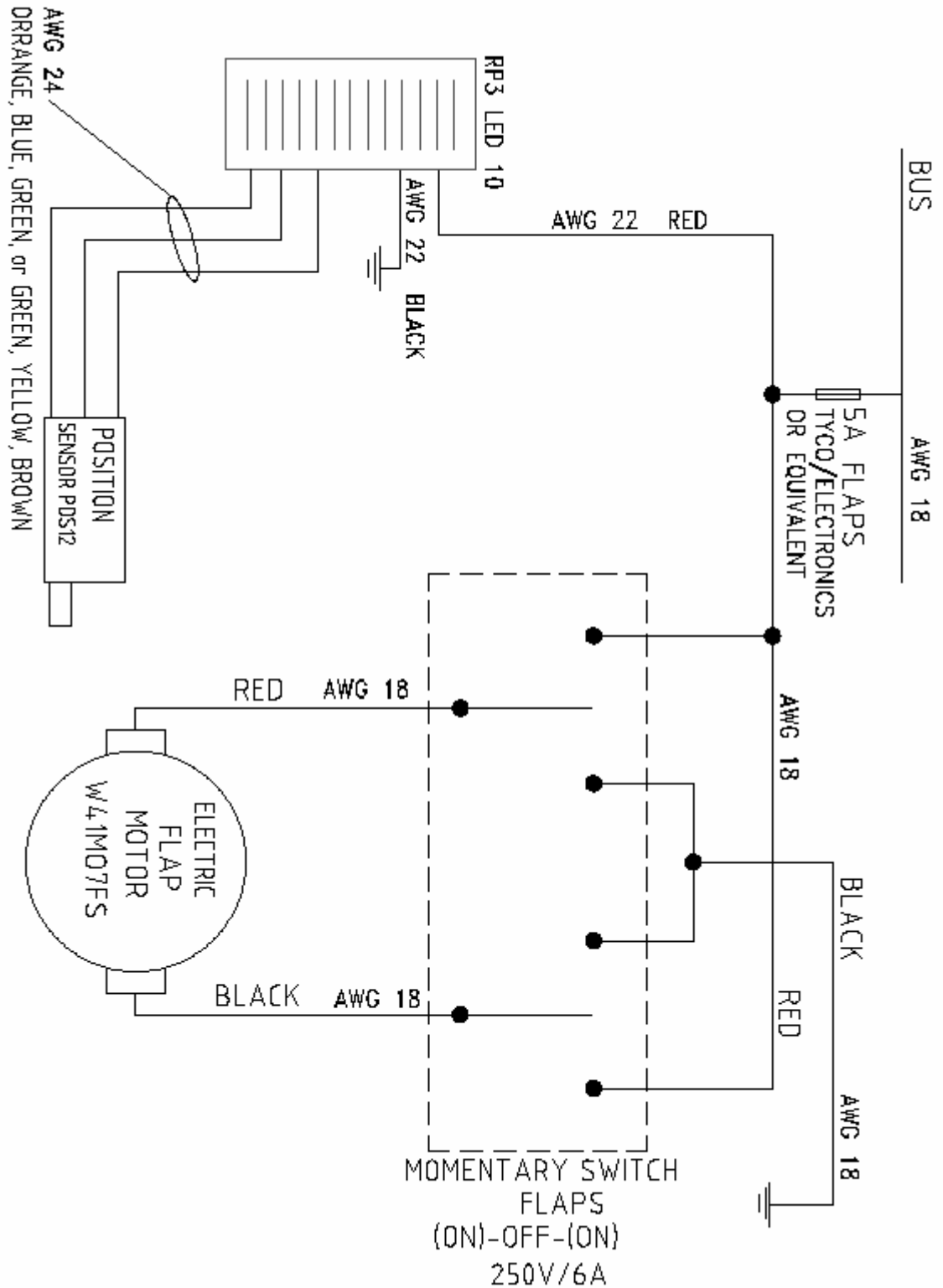

DRAWING 2 – MODIFIED FLAPS CONTROL SYSTEM

TECHNICAL BULLETIN

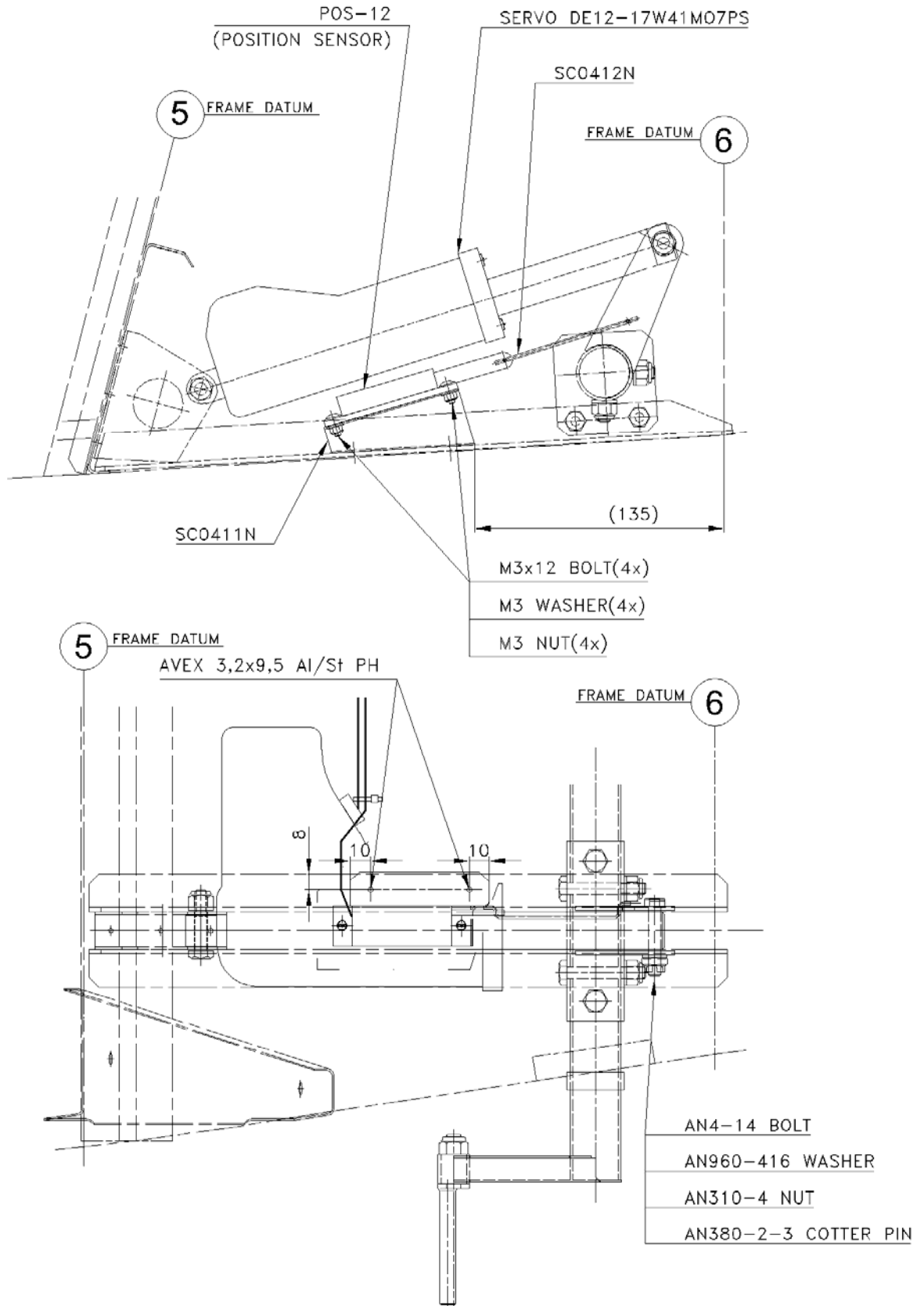

DRAWING 3 – FLAPS POSITION SENSOR INSTALATION

TECHNICAL BULLETIN



PICTURE 1 – LED Flaps position indicator



PICTURE 2 – Flaps sensor instalation